



Pipeline Equipment Resources Company, LLC

Natural Gas Expertise In Motion...

Natural Gas Tooling, Safety & Repair



**PRODUCTS
CATALOG | P6**



*Providing rugged tools
and game changing
technologies to the
natural gas industry
for over 25 years,
PERC focuses on building
long lasting, high quality
products that make your
job safer, simpler and
less time consuming.
Let us demonstrate
how PERC's natural gas
expertise in motion helps
you get it done!*

TABLE OF CONTENTS

Electrofusion Tooling

- 3 - PHOENIX ELECTROFUSION PROCESSOR
- 5 - PHOENIX ELECTROFUSION ACCESSORIES
- 6 - RITESCRAPE™ TUBING SCRAPERS
- 7 - RITESCRAPE™ ROTARY SCRAPERS
- 8 - RITESCRAPE™ MULTI-SIZE SCRAPERS
- 9 - RIBBON READER ELECTROFUSION MEASURING GAUGE
- 9 - FUSEMASTER ELECTROFUSION MEASURING GAUGE
- 10 - ALIGNRITE™ MAIN SIZE ALIGNMENT CLAMPS
- 11 - ALIGNRITE™ TUBING ALIGNMENT CLAMPS

Pipe Cutting & Squeeze Tools

- 13 - METFIT PLASTIC PIPE JOINING TOOLS
- 14 - REED PLASTIC PIPE CUTTERS
- 15 - TIMBERLINE PLASTIC PIPE SQUEEZE TOOLS
- 16 - PAC28 AXIAL WINDOW CUTTER

Repair & Safety Products

- 18 - STATIKIL PE ANTI-STATIC PROTECTION
 - 19 - LLFA® TAPE PIPE REPAIR
 - 20 - HALOVALVE NATURAL GAS SAFETY BREAKAWAY VALVE
 - 20 - WELDING BONDING CABLES
 - 21 - BAR PULLER FOR LEAK PROBING
 - 22 - NUPI ELECTROFUSION FITTINGS
-



FOLDS of HONOR

*A donation will be made to
Folds of Honor for every
Freedom Processor sold*

PERC Phoenix Electrofusion Processors are universal barcode processors that can identify and fuse fittings from any electrofusion fitting manufacturer.

All processors come with these industry leading features:

- Longer 17' Output Cables
- Wide Array Barcode Scanner with GPS Option
- Unique High Visibility/Low Temp Displays
- Center Balanced Watertight Enclosure with Easy Carry Handle
- USB or Bluetooth Connectivity
- Resistor ID Tip Option
- Calibration Lockout Capability & Operator Traceability Functions
- Battery Charge Life Display & Fitting Capacity Calculation
- Field Calibration with AUTOCAL®
- CALABUNGA C³ Calibration Control Center Compatible
- Made in the USA



Ask your representative about our calibration and repair services

PERC PHOENIX ELECTROFUSION PROCESSOR SPECIFICATIONS

SPECIFICATION	AC	FREEDOM	FREEDOM Lt
Universal	YES		
Operating Modes	Barcode, Manual & Resistor ID		
Size	20.625" x 16.875" x 8.125"	20.5" x 11.5" X 8"	19.125" x 15.5" X 7.5"
Weight	48 lbs	42 lbs	21 lbs
Output Cable Length	17 feet	17 feet	17 feet
Maximum Fitting Size	Any Fitting	12" Couplings	2" Couplings
Power Source	AC / Generator / Inverter	32 Ah Lithium Ion Battery	5 Ah Lithium Ion Battery
Supply Voltage	97 VAC - 150 VAC	120 VAC for charging only	120 VAC for charging only
Recharging Time	N/A	3.5 hours	1.5 hours
Supply Frequency	47 Hz - 70 Hz	60 Hz for charging only	60 Hz for charging only
Supply Waveform	Sine Wave or Square Wave	Sine Wave for charging only	Sine Wave for charging only
Output Voltage	8 - 48 volts +/- 2%		
Operating Temperature	0° F - 120° F (optionally 0° F - 140° F)		
High Visibility Display	60 Lux* (33% greater)		
Fusion Storage	5000+ Fusions		
Fitting Adapters Included	4.0mm / 4.7mm / Resistor ID		
Environmental Protection	IP54 Splash Proof		
Download Port / Connectivity	USB / Bluetooth		
Interface Compatibility	ControlPoint / EF Utilities		
Calibration Interval	1, 2 or 3 year (customer choice)		
Warranty	1 Year Standard (optional extended warranty)		

*Lux – A unit of measure for illuminance intensity which is a measure of how much luminance is spread over a given area



Ask your representative about our calibration and repair services



SMART SCANNER

- Scans barcodes with or without GPS capability.

Model	Part #
SmartScanner	306519
SmartScanner GPS	306520

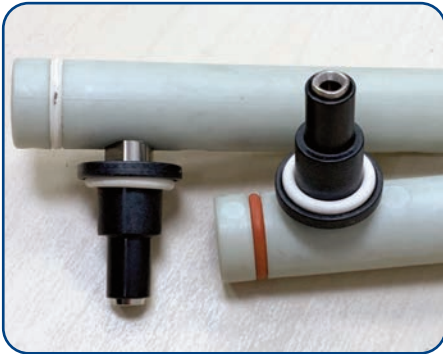

UNIVERSAL EF FITTING ADAPTER

- Universal adapter for 4.0mm and 4.7mm electrofusion fittings.
- Available with Resistor ID.

Model	Part #
Set of 2 universal adapters	306782



REPLACEMENT TIPS

- Screw in style for PERC Phoenix Processor.
- Older styles available. Please Call.

Size	Fittings*	Part #
4.0 mm (White)	Nupi Elofit, Innogaz, Friatec	306698
4.7 mm (Black)	Central, MT Deason	306699
4.7 mm (Black)	Central (Resistor ID)	306701
–	Wrench	301506
–	Marinco Adapter	301787

NEW
quick blade
release lever
and tapered
mandrel

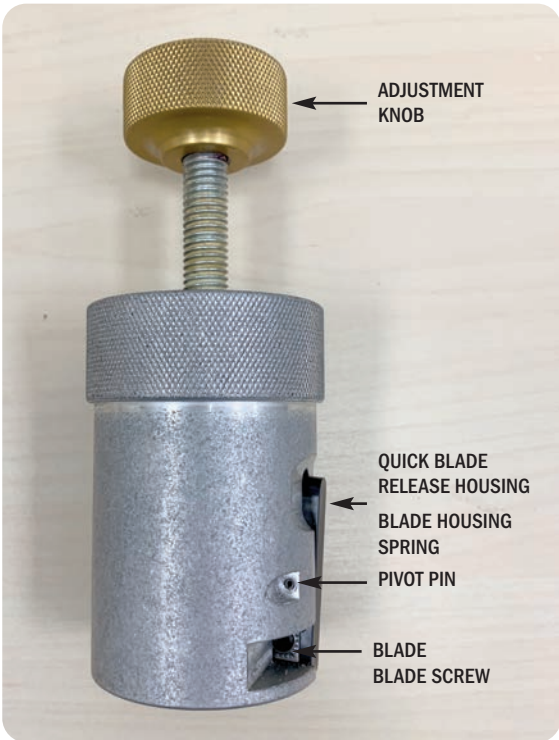

RITESCRAPE™ TUBING SCRAPERS V2

- Machined billet aluminum construction
- Floating 4-sided blade for consistent shaving depth even on coil or ovaled pipe
- Ideal for pipe prep on couplings and tees.
- 1/2" CTS through 2" IPS
- Tapered Mandrel for different wall thickness for same size tubing.

Model	Tubing Size	Part #
RITESCRAPE Tubing Scraper V2	1/2" CTS	308378
	3/4" IPS	308379
	1" CTS	308380
	1" IPS	308381
	1-1/4" CTS	308382
	1-1/4" IPS	308384
	2" IPS	308385

REPLACEMENT PARTS FOR ALL SIZES

Adjustment Knob	Blade	Blade Screw
304179	303653	303958

REPLACEMENT PARTS PER TOOL

Blade Housing Spring (for 1/2" CTS - 1-1/4" IPS)	Quick Blade Release Housing (for 1/2" CTS - 1-1/4" IPS)	Blade Housing Pivot Pin (for 1/2" CTS - 1-1/4" IPS)	Blade Housing (for 2")	Blade Housing Bolt (for 2")
310543	310544	310545	310529	310530



All field maintainable and repairable



RITESCRAPE™ SINGLE SIZE ROTARY SCRAPERS V3

- Machined billet aluminum construction
- Floating blade for consistent shaving depth even on coil or ovaled pipe
- Same parts across all sizes
- Smaller profile for use in tight work areas
- 1-1/4" IPS through 12" main sizes

Model	Pipe Size	Part #
RITESCRAPE Rotary Scraper V3 (Includes Bag)	1-1/4" IPS	308885
	2" IPS	308817
	3" IPS	308886
	4" IPS	308818
	6" IPS	308819
	8" IPS	308887
	12" IPS	308888

Model	Part #
Insert Stiffener for 1-1/4" & 2" Pipe	303599

REPLACEMENT PARTS

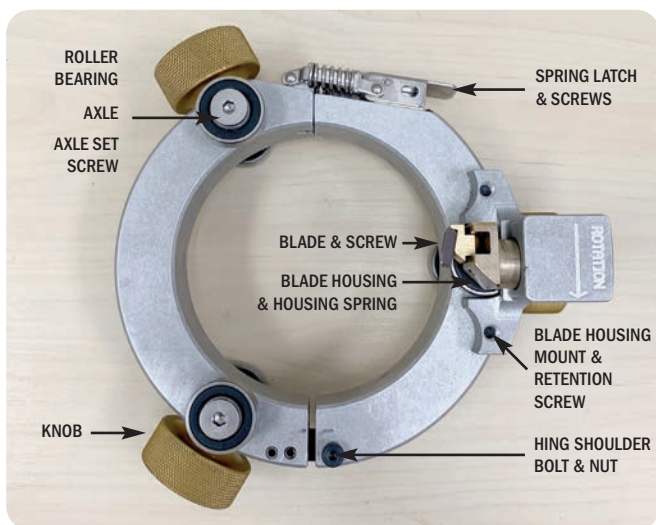

Replacement Parts For All Size Scrapers	Part #
Blade (Single Edge)	308854
Blade Housing	308880
Blade Housing Mount	308874
Blade Housing Retention Screw	308883
Blade Housing Spring	304585
Hinge Shoulder Bolt & Nut	308912
Top Roller Bearing, Axle, Set Screw	Please Call
(2) Bottom Roller Bearings, Axles & Set Screws per tool size	Please Call
(3) Bottom Roller Bearings, Axles & Set Screws for 1-1/4" only	Please Call
Small Padded Bag (for 2" & 4")	301961
Large Padded Bag (for 6" & 8")	301962
X-Large Padded Bag (for 12")	301956

Replacement Parts For Previous Models	Part #
Blade (4-sided)	303653
Blade Screw	303958



All field maintainable and repairable

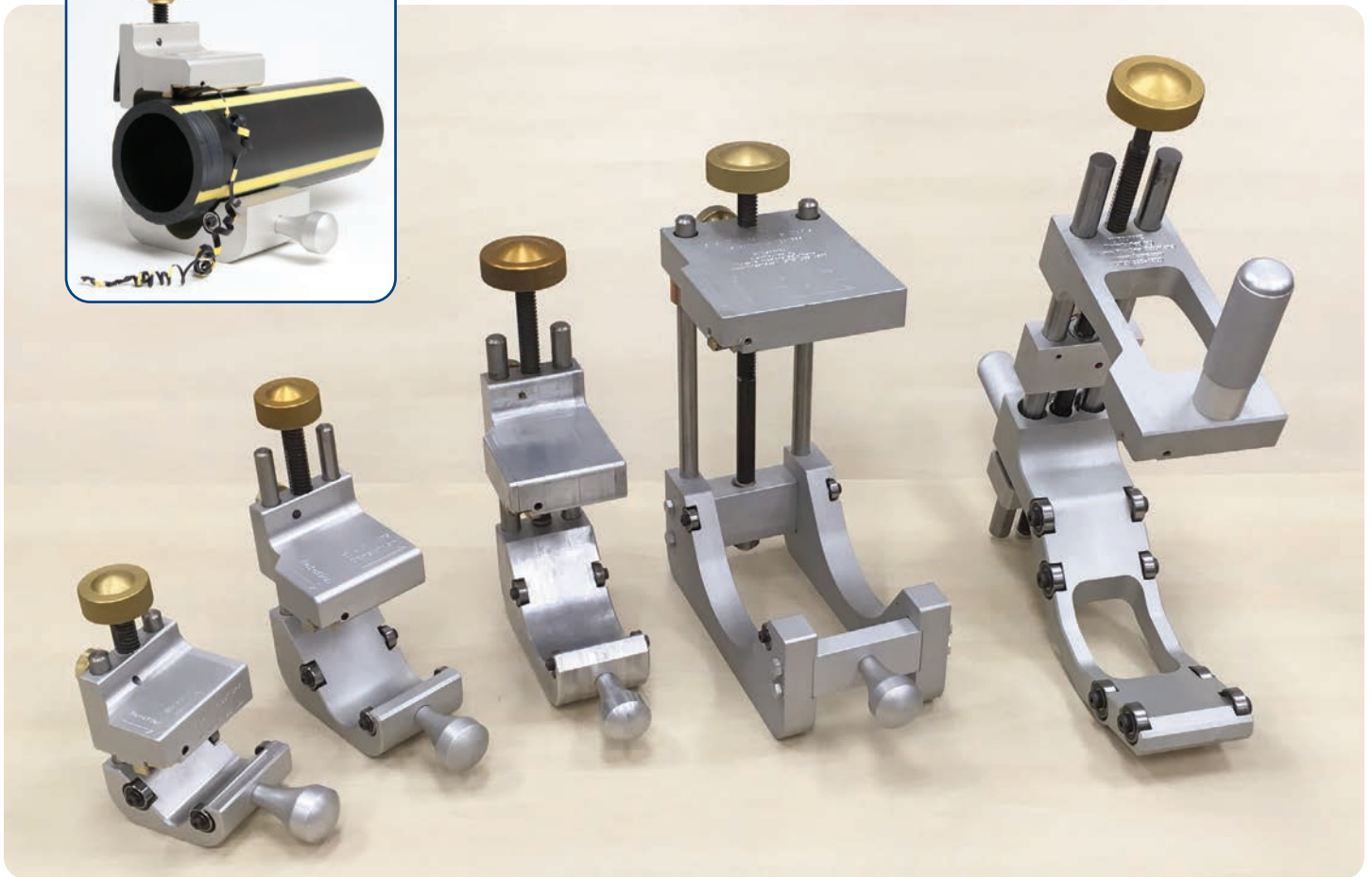

RITESCRAPE™ MULTI-SIZE SCRAPERS

- Machined billet aluminum construction
- Floating 4-sided blade for consistent shaving depth even on coil or oveled pipe
- Each tool handles multiple pipe sizes.
- 1-1/4" IPS through 12" main sizes available.

Model	Pipe Size	Part #
RITESCRAPE Multi-Size Scraper	1-1/4" - 2" IPS	307206
	2" - 4" IPS	307207
	4" - 6" IPS	309588
	6" - 8" IPS	303589
	6" - 12" IPS	310415
Carrying Case for 2" - 4" and 6" - 8" IPS		304215

RITESCRAPE™ MULTI-SIZE SCRAPERS REPLACEMENT PARTS

Tool	Adjustment Knob	Adjustment Screw	Lock Knob	Lock Insert	Housing	Blade	Housing Spring	Blade Screw	Roller Bearing	Post	Shoulder Bolt
1-1/4" - 2" IPS	304179	309572	303964	304178	303957	303653	303959	303958	303961	310105	303962
2" - 4" IPS		310104								304114	
4" - 6" IPS		304416								310146	
6" - 8" IPS		303841								310075	
6" - 12" IPS	310106	310269	303843	303842				304115	N/A	304116	



All field maintainable and repairable

RITE SCRAPE™ MULTI-SIZE SCRAPERS REPLACEMENT PARTS

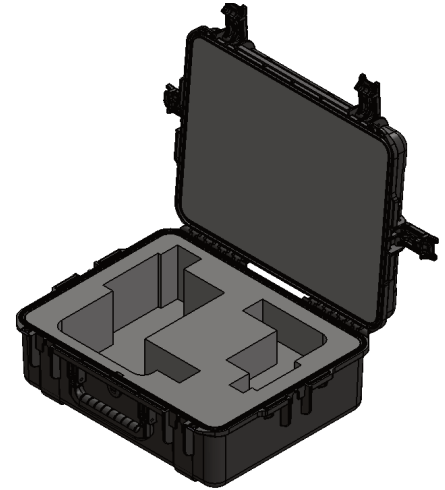
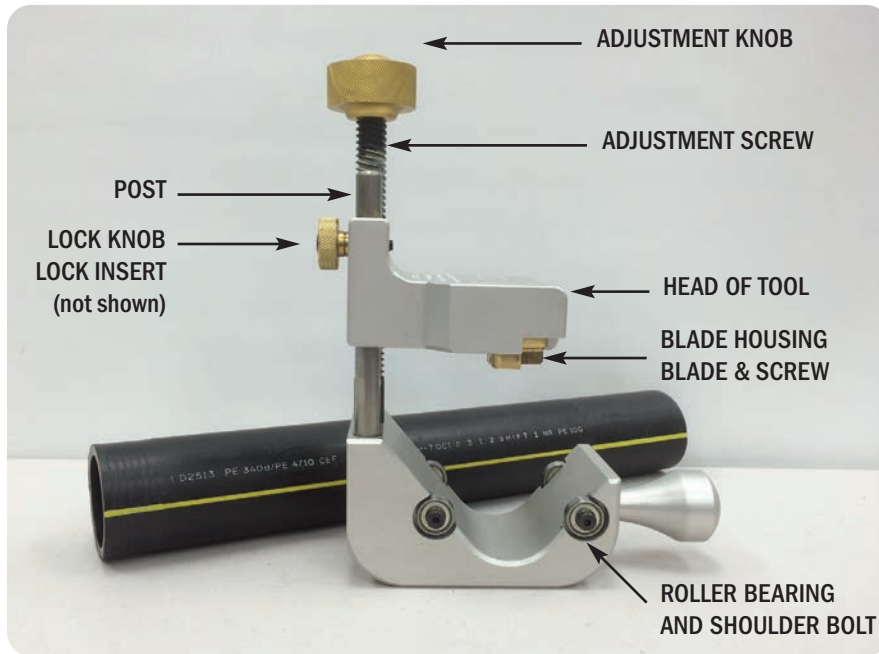

*Carrying Case for
2" - 4" and 6" - 8" IPS*

RIBBON READER ELECTROFUSION MEASURING GAUGE

- Stainless-Steel tool designed to measure the thickness of PE ribbon.
- Precisely slotted at measurements of .005"-.019" (odd numbers only).
- Size of a credit card to fit in a wallet.

Product	Size Range	Part #
Ribbon Reader	.005" - .019" (odd #'s only)	310979



FUSEMASTER ELECTROFUSION MEASURING GAUGE

- Meets all standards requirements.
- Peel/ribbon thickness gauge, gouge, gap & out of roundness indicators, and pipe wall thickness chart - all in one tool.
- Pipe sizes from 1" to 12" .

Product	Size Range	Part #
FM16-19	1" - 6" Pipe	305500
FM212-19	2" - 12" Pipe	305499



ALIGNRITE™ STANDARD ELECTROFUSION CLAMPS

- High quality billet aluminum construction
- Liners available for multiple size configurations

Model	Tubing/ Pipe Size	Part #
ALIGNRITE Adjustable Clamp	2" IPS	304506
Liner Set (NEW size now available)	1-1/4" CTS	310487
Liner Set	1-1/4" IPS	304507
Liner Set (NEW size now available)	1" CTS	310488
Liner Set (NEW size now available)	1" IPS	310489
ALIGNRITE Adjustable Clamp	8" IPS	305799
Liner Set	6" IPS	304592
Liner Set (Requires 6" liner set for base)	4" IPS	305800
ALIGNRITE Straight Clamp	4"	304588
Liner Set	3"	304591
Liner Set (Requires 3" liner set for base)	2"	304590
ALIGNRITE Straight Clamp	8"	304589
Liner Set	6"	304592
Liner Set (Requires 6" liner set for base)	4"	304646
ALIGNRITE Hoop Style Straight Clamp	12"	304227



12" hoop style straight clamp

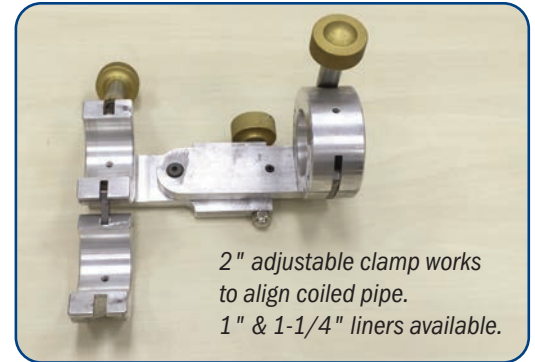

2" adjustable clamp works to align coiled pipe. 1" & 1-1/4" liners available.

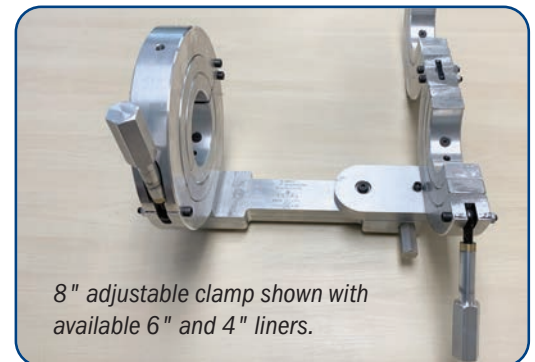

8" adjustable clamp shown with available 6" and 4" liners.



8" straight clamp. 4" & 6" liners available.

ALIGNRITE™ ARTICULATING ELECTROFUSION CLAMP

- Articulating arms with fixed positions at straight, 45° & 90°.
- 2" & 3" liners available.
- Adjustable mechanism for coiled pipe.

Model	Tubing/ Pipe Size	Part #
ALIGNRITE Articulating Clamp	4"	305783
Liner Set	3"	304591
Liner Set (Requires 3" liner set for base)	2"	304590

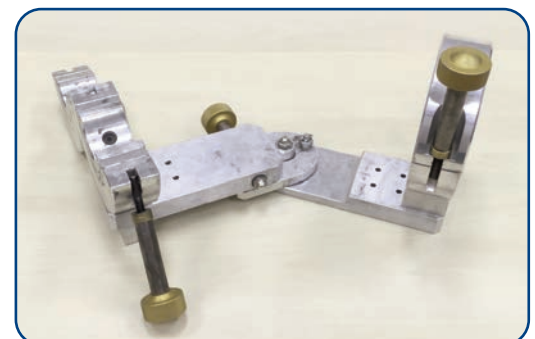

All field maintainable and repairable



ALIGNRITE™ V-STYLE ELECTROFUSION CLAMP

- One tool for aligning 2" - 6" or 6" - 12" pipe.
- Quick release ratchet straps used to secure pipe.

Model	Tubing/Pipe Size	Part #
ALIGNRITE V-Style Clamp	2" - 6"	304638
ALIGNRITE V-Style Clamp	6" - 12"	304195

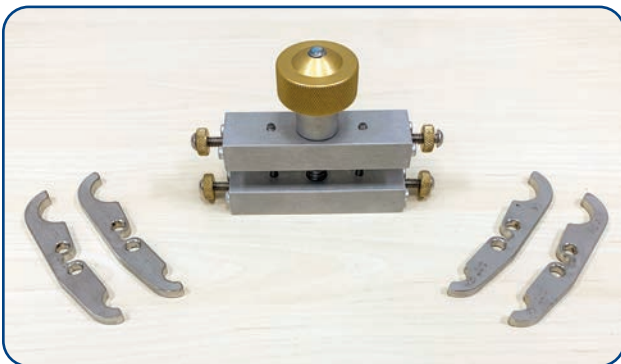

ALIGNRITE™ MINI ELECTROFUSION CLAMP

- Designed for 1/2" CTS through 1-1/4" IPS Tubing
- Purchased as Core Body only with various sized Dual-Sided Liners
- 3-in-1 design for size-on-size and Reducer Couplings (Choose 2 sizes)

Model	Part #
ALIGNRITE Mini Clamp - Core Body Only	311051

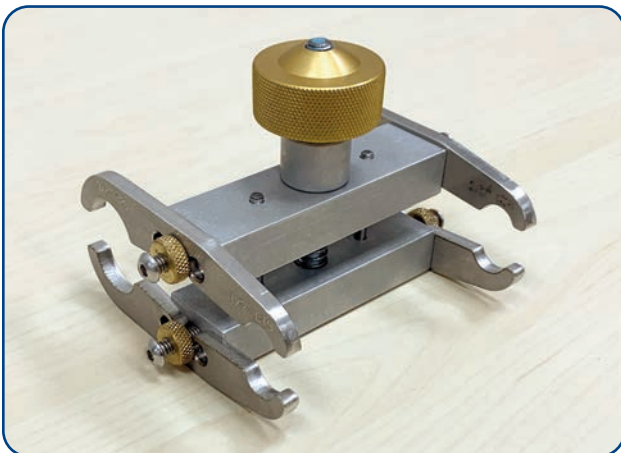

Model	Tubing/Pipe Size	Part #
ALIGNRITE Mini Clamp Dual-sided Liners	3/4" IPS x 1/2" CTS	311052
	1" CTS x 1/2" CTS	311053
	1" CTS x 3/4" IPS	311054
	1" IPS x 1/2" CTS	311055
	1" IPS x 3/4" IPS	311056
	1" IPS x 1" CTS	311057
	1-1/4" IPS x 1/2" CTS	311058
	1-1/4" CTS x 3/4" IPS	311059
	1-1/4" IPS x 3/4" IPS	311060
	1-1/4" CTS x 1" CTS	311061
	1-1/4" CTS x 1" IPS	311062
	1-1/4" IPS x 1" IPS	311063
	1-1/4" IPS x 1" CTS	311064
	1-1/4" IPS x 1-1/4" CTS	311065



All field maintainable and repairable



ALIGNRITE™ ELECTROFUSION TUBING CLAMPS

- Sizes 1/2" - 2" IPS available
- High-quality Milwaukee vise grips
- Sizes clearly etched on clamps
- Specialty sizes available by request

Model	Tubing/Pipe Size	Part #
ALIGNRITE Vise Grip Clamp	1/2" CTS	304135
	3/4" IPS	304146
	1" CTS	304155
	1" IPS	304156
	1-1/4" CTS	304139
	1-1/4" IPS	304157
	1-1/2" IPS	310551
	2" IPS	304158

Model	Tubing/Pipe Size	Part #
ALIGNRITE 90° Elbow Vise Grip Clamp	1/2" CTS 90°	309631
	1" CTS 90°	306369
	2" CTS 90°	304230
	1-1/4" CTS 90°	306808
	1-1/4" IPS 90°	306822

Model	Tubing/ Pipe Size	Part #
ALIGNRITE Vise Grip Clamp	2" IPS x 1" CTS	304160
	1-1/4" IPS x 1" IPS	304153
	1-1/4" IPS x 1/2" CTS	304151
	1-1/4" CTS x 1"IPS	304152
	1-1/4" CTS x 1" CTS	304161
	1" IPS x 1" CTS	304159
	1" CTS x 1/2" CTS	304144
	1" CTS x 3/4"IPS	304142
	1" IPS x 3/4"IPS	304143
	1" CTS x 3/4" CTS	304145
	2" IPS x 1-1/4" IPS	304147
	1/2" IPS x 1/2" CTS	304148
	3/4" IPS x 1/2" IPS	304149
	1-1/2" IPS x 1" CTS	304154
	1-1/4" IPS x 1-1/4" CTS	304150
	1-1/4" IPS x 1" CTS	304136
	1" IPS x 1/2"CTS	304137
	2" IPS x 1" IPS	304138
	3/4" IPS x 3/4" CTS	304140
	3/4" IPS x 1/2" CTS	304141
	1-1/2" CTS x 1"IPS	305587
	2" IPS x 1-1/2" IPS	307730
	1-1/2" IPS x 1-1/4" IPS	307731



Nutcracker



V-Tool



Adapter Jaws

JM EAGLE METFIT® INSTALLATION TOOL

- Effectively joins MetFit brand fittings.
- Nutcracker - dedicated 1/2" CTS tool.
- V-Tool - 1/2" CTS to 1-1/4" CTS with proper jaws.

Model	Tubing/ Pipe Size	Part #
Nutcracker	1/2" CTS	304989
V-Tool	1/2" CTS - 1-1/4" CTS	304889
Adapter Jaws	1/2" CTS	302399
Adapter Jaws	1/2" IPS - 3/4" CTS	302400
Adapter Jaws	3/4" IPS	302401
Adapter Jaws	1" CTS	302402
Adapter Jaws	1" IPS - 1-1/4" CTS	302403
Replacement Pins	Set of 2	302406

JM EAGLE METFIT® SERIES 200 HYDRAULIC SYSTEM



Model	Tubing/ Pipe Size	Part #
Series 200 Tool (no pump)	Includes 2" liners	305229
Series 200 System	Includes tool, pump, hose, 2" IPS liners only	303821
Series 200 System	Includes tool, pump, hose, 1-1/4" IPS and 2" IPS liners	303279
Adapter Jaws	2" IPS	302405
Adapter Jaws	1-1/4" IPS	302404
Adapter Jaws	1-1/2" IPS	303866
Relief Valve	For Series 200	303805
Hydraulic Pump	Dual Stage	303335
Hydraulic Hose	For Series 200	304597
Hydraulic Pump Oil	For Series 200	304214



Ask your representative about our tool repair services

PLASTIC PIPE CUTTING TOOLS

888-232-PERC (7372)
www.perc.us.com

REED RATCHET SHEARS

Model	Tubing/Pipe Size	Part #
RS1	Cuts through 1-1/4" CTS	302374
RS1PLT	RS1 with Corrosion Resistant Blade	302376
RS2	Cuts through 2"	302377
RS7290	Cuts 2" PE Pipe and PVC	303160

Model	Description	Part #
RS1B	RS1 Blade	302375
RS1BPLT	RS1PLT Plated Blade	309626
RS2B	RS2 Blade	302378
RS7290B	RS7290 Blade (fits Wheeler 7290)	306797
All	PEGRM Static Grounding Device	307248



REED IN-LINE ROTARY CUTTER

- Creates no dust and chips fall where they are cut.
- Only 6"-8" clearance needed to turn PLAS around pipe.

Model	Tubing/Pipe Size	Part #
PLAS1PE	Cuts through 6" - 12" PE Pipe	304095
PLASPEB	Replacement Blade	304108



REED GUILLOTINE CUTTERS

Model	Tubing/Pipe Size	Part #
HPC4+	2" - 4"	307954
HPC8+	3" - 8"	306396
HPC12	4" - 12"	302370

Model	Description	Part #
HPC4B	HPC4 / HPC4+ Blade	302372
HPC8B	HPC8 / HPC8+ Blade	302373
HPC12B	HPC12 Blade	302543



NEW
2"-4" & 3"-8"
all aluminum
body. 22%
lighter!



SEE PARTS LISTS



Rotating sleeve gives you 3 sizes in one tool.

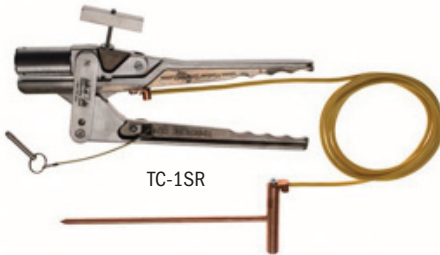

Grounding rod and locking pin sold separately

TC-1 / TC-1SR / TC-2 TOPSIDE CLAMPS

- Rotating sleeve adjusts for multiple pipe sizes.
- Extension handles available. Custom lengths available.
- Customer must select multiple pipe sizes per unit.

Model/Part	Tubing/Pipe Size	Part #
TC-1	1/2" CTS - 1-1/4" CTS	Please Call
TC-1SR (slow release)	1/2" CTS - 1-1/4" CTS	Please Call
TC-2	1/2" CTS - 2" IPS	Please Call
Grounding rod	With solid copper wire	303297
Locking Pin	NA	302910
Case	TC-1 + Grounding Rod	303941



TR650

TR170 TOP REACH CLAMP

Top-down remote squeeze-off solution for 1/2" - 1-1/4" CTS.

- Length: 6.5' / Width: 6.0" / Weight: 23.0 lb.
- Standard Equipment:
 - Grounding rod with 10' copper cable.
- Customer must select 3 pipe sizes per unit.

TR270 TOP REACH CLAMP

Top-down remote squeeze-off solution for 1/2" CTS - 2" IPS.

- Length: 6.5' / Width: 10.5" / Weight: 19.0 lb.
- Standard Equipment:
 - 4 slap-on jaws specific to customer pipe sizes.
 - Hard carrying case.
 - Grounding rod with 10' copper cable.
- Customer must select 4 pipe sizes per unit.

TR650 TOP REACH CLAMP

Top-down remote squeeze-off solution for 3" - 6" IPS.

- Length: 6.5' / Width: 17.8" / Weight: 116 lbs.
- Standard Equipment:
 - Hard carrying case.
 - Grounding rod with 10' copper cable.
- Customer must select 2 pipe sizes per unit.



Model	Tubing/Pipe Size	Part #
TR170	1/2" CTS - 1-1/4" CTS	Please Call
TR270	1/2" CTS - 2" IPS	Please Call
TR650	3" IPS - 6" IPS	Please Call

PAC28 PIPE AXIAL CUTTER

888-232-PERC (7372)
www.perc.us.com

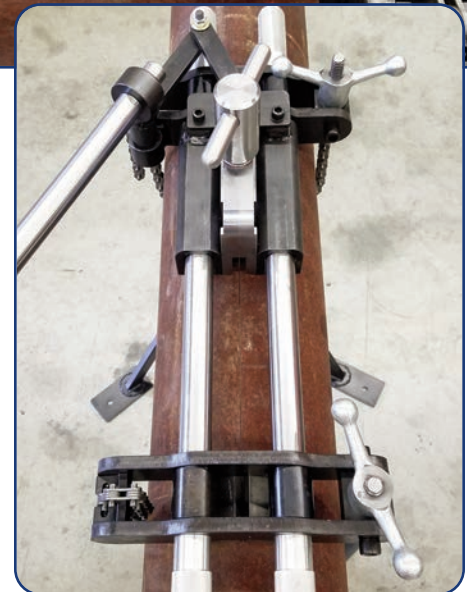

PAC28 PIPE AXIAL CUTTER

- Make spark-less longitudinal cuts on 2" - 8" steel or cast iron pipe without damaging PE pipe inside.
- Use a standard four wheel cutter. (see below) to effectively remove a section of casing pipe.
- Weighing less than 75 lbs allows for single man operation.
- Rugged machined steel components and hardened cutter wheels.
- Easily field maintained.

Model	Part #
PAC28	304759
Spare Cutter Wheels (2 per tool required)	304770

REED 4 WHEEL HINGED CUTTERS

- Requires only 90° - 100° swing range.
- Only needs 4" clearance around pipe.
- 2" - 12" range.
- Cuts steel, stainless steel, cast and ductile iron.

Model	Tubing/Pipe Size	Part #
H4S	2" - 4"	303969
H6S	4" - 6"	303349
H8S	6" - 8"	304503
H12S	8" - 12"	303350

Full assortment of replacement cutter wheels available



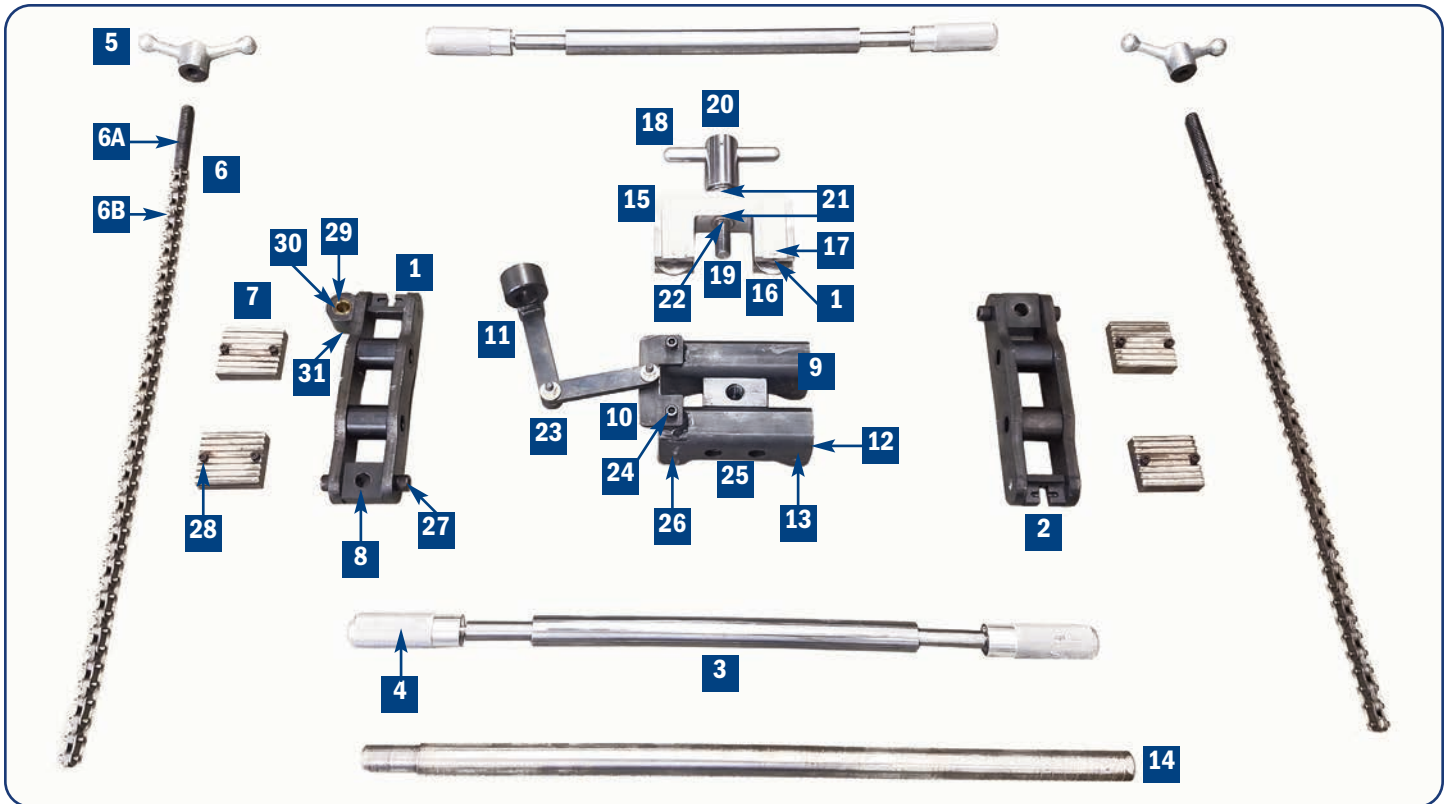

PAC28 REPLACEMENT PARTS

Ref. No.	Description	Part #	Pieces per tool
1	Left Support (w/hole for Pivot Link)	304760	1
2	Right Support	310510	1
3	Support Bar (w/out hand grips)	304761	2
4	Hand Grip	304762	4
5	Chain Handle	304763	2
6	Link Chain and Threaded Rod Screw Assembly	304764	2
6A	Threaded Rod Screw Assembly	304766	2
6B	Link Chain	304765	2
7	Jaw	310252	4
8	Pivot Block	310253	2
9	Carriage	310502	1
10	Mounting Plate	304767	1
11	Pivot Link Assembly (Includes Bolts/Nuts/Washers)	304768	1
12	Roller	301636	4
13	Roller Pin	301637	4
14	Operating Handle	304769	1
15	Yoke	310503	1

Ref. No.	Description	Part #	Pieces per tool
16	Cutter Wheel (Generic wheels can be used but not recommended)	304770	2
17	Cutter Wheel Pin	304771	2
18	Feed Screw Crank	310504	1
19	Feed Screw	310505	1
20	Feed Screw Crank Pin	310506	1
21	Thrust Bearing	304772	2
22	Feed Screw Pin	304773	1
23	Bolt/Nut/Washers for Pivot Link Assembly	304774	2
24	Mounting Plate Allen Screws	310255	2
25	Carriage Screws	310256	1
26	Cutter Wheel Retention Screws	304775	8
27	Pivot Block Screw	310257	4
28	Jaw Allen Screws	310258	8
29	Brass Bushing for Left Support	304776	1
30	Brass Washers	304777	2
31	Snap Ring	304778	1



Excellent visibility on all PE pipes



- Effectively eliminates static charges on PE gas pipe by increasing surface conductivity
- Eliminates need for bulky burlap or pipe wraps
- Keeps work area clear and eliminates trip hazards posed by other grounded pipe “wraps”
- To be used prior to construction operations including squeeze-off, repair, tapping, cutting, venting, etc.
- Colorant added for positive verification of product coverage
- Remains effective even after pipe is dry
- No aerosols. No wasted over spray.

Product available ready for use in:

- 32 oz spray bottle with simple trigger spray for accurate application. (Part # 301000)
- 1 Gallon containers (Part # 301813)



ProReach128 (one gallon) long reach sprayer accessory available for above ditch applications (Part # 306035)

Specifications

Composition	High Molecular Weight Topical Antistat
Physical Form	Liquid
Color	Gray Pigment for Visibility
Flash Point	None
Freeze Point	-10° F
Explosion Hazard	None
Specific Gravity	1.0
Odor	Mild Lemon
pH Regular	7.71
Static Decay Rate	MIL-B-81705-B At Relative Humidity @13% 72°F .35 Sec @5 KV

STATIKIL PE has been tested by independent laboratories and meets or exceeds ASTM D-257-80, MIL B-81705-B, Electronic Industry IS-5 and NFPA-99 specifications for surface resistivity and static decay.

Health 0	Flammability 0
Reactivity 0	



PLEASE VISIT WWW.STATIKIL.COM TO SEE A VIDEO OF STATIKIL PE IN ACTION!

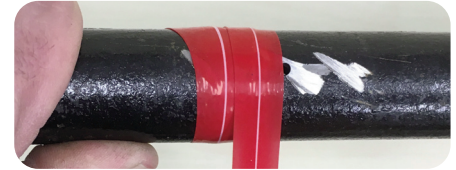
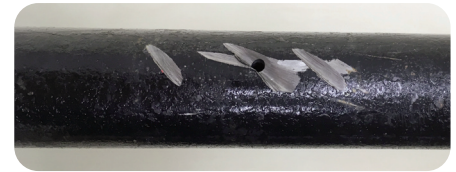

LLFA® TAPE

LLFA Tape is a self-fusing silicone based tape designed to seal leaks in harsh weather conditions and is currently used as a temporary or permanent repair for natural gas leaks.

- LIVE leak sealing <150psi on PE, Steel, Copper, Cast Iron, SST, etc.
- One-step, straightforward application with minimal prep time.
- Stable from -130°F to 500°F (-90°C to 260°C).
- Highly UV & Ozone resistant.
- No storage requirements, 4 year shelf life.

LLFA® SMOOTH

Fast-acting insulating putty that stays flexible and works well in conjunction with LLFA Tape.

- Fill rough and/or uneven surfaces before using LLFA Tape.
- Molds quickly and easily, without the use of gloves or chemicals.

LLFA® GARDE

Moisture cure polyurethane infused fiberglass tape for extra protection of LLFA Tape in extremely aggressive/abusive environments.



RESOURCE LIBRARY

Model	Description	Part #
LLFA Tape	1" x 40mil x 36ft (Red)	301819
	1" x 40mil x 36ft (Black)	301822
	2" x 40mil x 36ft (Red)	301824
	1" x 40mil x 12ft (Red)	301820
LLFA Smooth	4oz, 113g (Standard)	301826
	3oz, 100g (Thin)	301828
	4"X 6" (Brick)	301830
LLFA Garde	3" x 5'	306047
	3" x 12'	306048
	4" x 12'	307618
V65 Tensioner	2" Tape Tensioner	301832

HALOVALVE

The HaloValve is a Natural Gas Safety Breakaway valve, which can be easily integrated into existing installations, it is placed in the riser pipe between grade and the gas meter. Upon impact, the valve disconnects and gas flow is shut off, which provides instant and effective protection from the accidental rupture of gas meter lines.

Additionally, the HaloValve enables utility companies to comply with the requirements of the PIPES Act legislation of 2020 by helping eliminate the accidental emission of greenhouse gases into the atmosphere.

- The breakaway valve is installed into the meter set or other gas piping.
- Design withstands nominal lateral forces.
- If a significant lateral force occurs, the fitting breaks.
- The ball acts as a plug stopping the escape of gas.
- Stopping the flow of natural gas minimizes risk of fire, explosion, property damage and serious injury.

Model	Size	Part #
HaloValve	3/4"	Please Call
	1"	Please Call

Available in 4" & 6" lengths and any combination MNPT or FNPT connections.

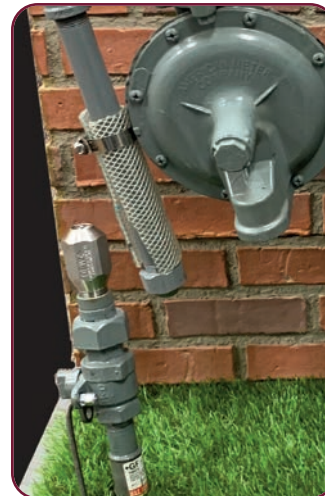
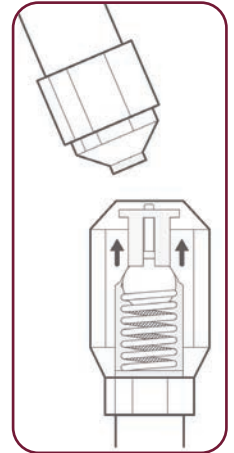
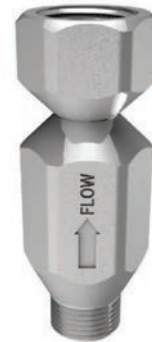

BONDING CABLES

Maintain continuity between two pipe sections when welding to ensure both have adequate path to ground for safe and effective welds.

Lengths Available	Part #
6' Bonding Cable Assembly (Magnetic)	304925
10' Bonding Cable Assembly (Magnetic)	304923
20' Bonding Cable Assembly (Magnetic)	304924
6' Bonding Cable Assembly (Spring Clamp)	306683



Standard Magnetic Ends



Spring Clamp Ends



Model	Part #
Bar Puller	304920

PERC BAR PULLER

- All welded steel design.
- Lightweight at less than 20 lbs. total weight.
- Designed for one man operation.
- Prevents pavement cracking.
- Eliminates bar bending caused by other removal methods.
- Adjustable to bar/pin diameters of 1/2" - 1-1/4".
- Pull stuck pneumatic tool bits from pavement and concrete.
- Works on all ground surfaces during all seasons.

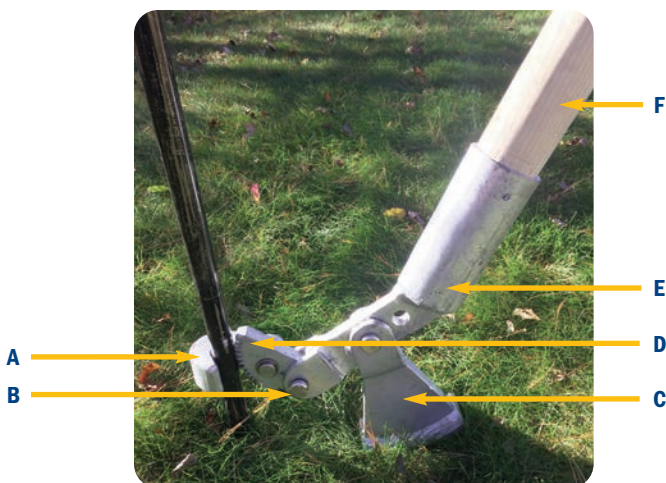

REPLACEMENT PARTS

Ref	Description	Part #
A	Hook	301638
B	Hook/Jaw/Rocker Pin with Snap Ring	301562
C	Rocker	301640
D	Ratchet Jaw	301639
E	Lever	301641
F	Ash Wood Handle (6')	301148

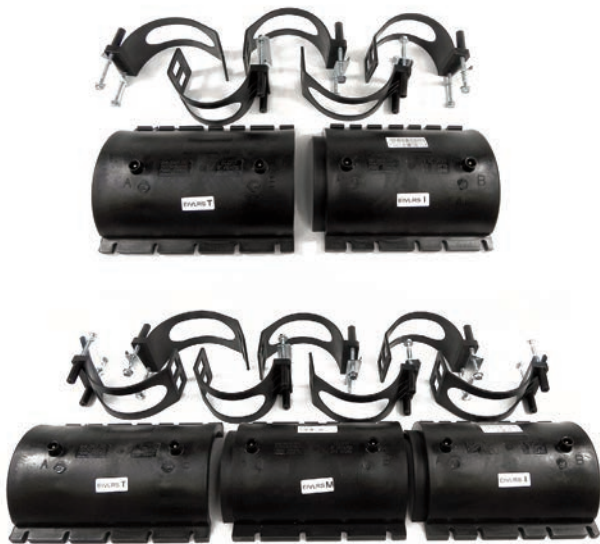

NUPI VARIABLE LENGTH REPAIR SLEEVE (VLRS)

The Variable Length Repair Sleeve (VLRS) is a modular system of electrofusion shells that can be installed contiguously and welded on pipes that have notches, scrapes or damage along the axis.

- Rated up to 60 psi.
- Effective on all PE resins.
- Undersaddle clamp included for ease of installation.
- Universal barcode technology to complete fusion.

Model	Pipe Size	Part #
Standard Assembly	2" IPS - 180°	304820
	4" IPS - 180°	304823
	6" IPS - 180°	304825
Middle Assembly	2" IPS - 180°	304821
	4" IPS - 180°	304824
	6" IPS - 180°	304826
Jumper Cables	All	303992



NUPI BUTT FUSION REPAIR SLEEVE (BFRS)

The Butt Fusion Repair Sleeve (BFRS) is a safety/repair system to be used to permanently reinforce suspect butt fusion welds.

- Effective on all PE resins.
- Universal barcode technology to complete fusion.
- Clamps and cables sold separately.

Model	Pipe Size	Part #
Standard Assembly	2" IPS - 360°	304827
	4" IPS - 360°	304819
	6" IPS - 360°	304822
	8" IPS - 360°	304828
Installation Kit	12" IPS - 360°	304829
	Includes wrench, clamps, & jumper wires	302030
Jumper Cables	All	303991

SEE OUR ELECTROFUSION MEASUREMENT GAUGES ON PAGE 9



NUPI TAPPING TEES

- 1-1/4" - 12" main sizes with 1/2" CTS - 2" IPS outlets available.
- Service and high volume sizes available for SPT & HVPT.
- Unique dual seal, no blow tapping performance.
- Multiple levels of quality control.
- No special installation tools needed; plastic or strap underclamp included with every fitting.



NUPI ELECTROFUSION COUPLINGS

- 1/2" service to 12" main available.
- Multiple levels of quality control.
- Specialty reducers, elbows, tees, and endcaps available.

NUPI CAMERA & BRANCH SADDLES

- Camera fittings come standard with completion plug for a gas tight seal.
- No special tools needed, plastic or strap underclamp included with every fitting.
- Electrofusion branch saddles as large as 12" x 6" available for easy main extension projects.
- NPT series available.

Please contact us for help in ordering the correct size for your application.



Pipeline Equipment Resources Company, LLC

Natural Gas Expertise In Motion...

Corporate Office
9 Mars Court
Boonton, NJ 07005
t: 888-232-PERC (7372)
info@perc.us.com
www.perc.us.com

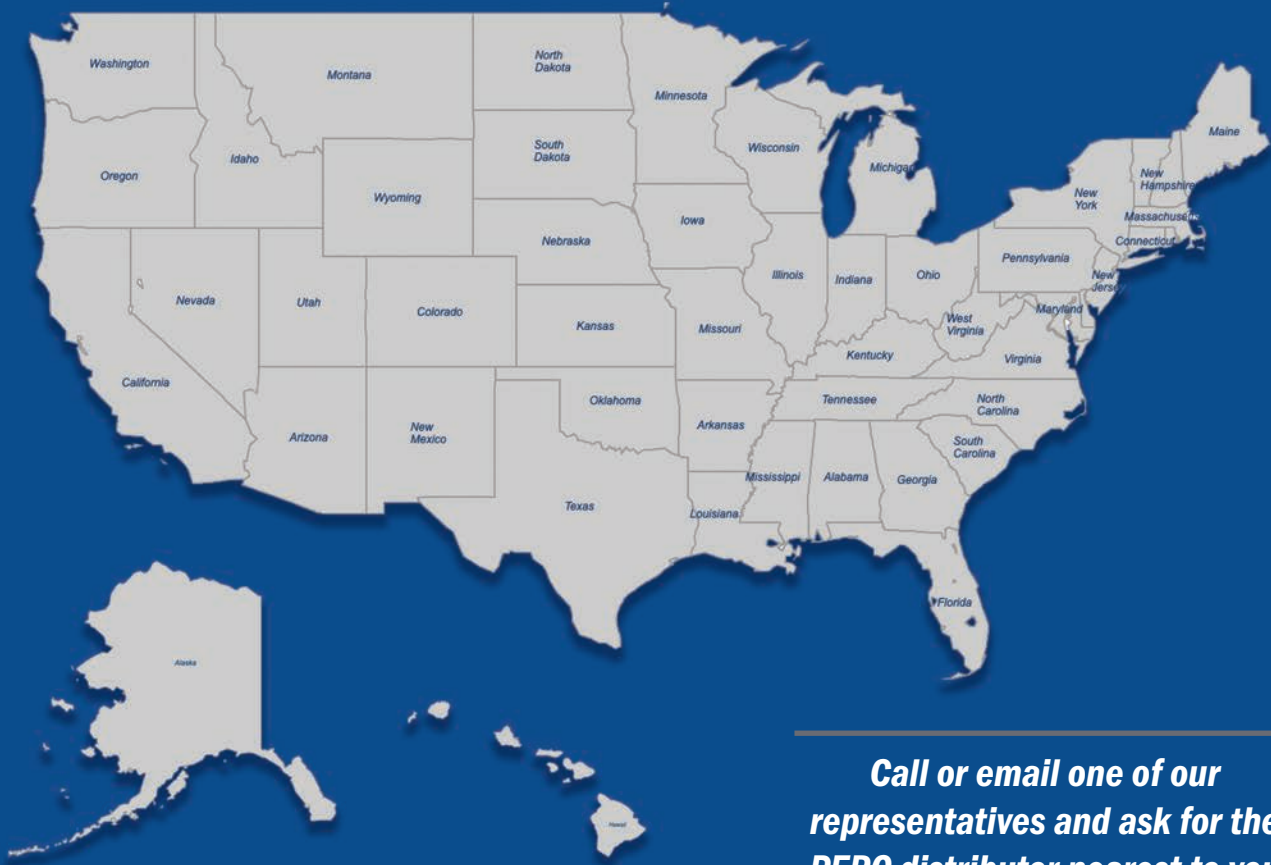

***Call or email one of our
representatives and ask for the
PERC distributor nearest to you***



Anthony Dunkley
National Sales Manager
416-788-4549
adunkley@perc.us.com



Kevin Schwartz
Tooling & Distribution Manager - National Sales
716-385-2936
kschwartz@perc.us.com



Eddie Ballo
Inside Sales
973-216-1490
eballo@perc.us.com



John Zuccaro
Technical Manager
781-424-5995
jzuccaro@perc.us.com