



A CLEAN BREAK FROM OUTDATED GAS METER PROTECTION.

INTRODUCING

Halo
Valve

**NATURAL GAS
BREAKAWAY**

The Safety Breakaway that Stops Leaks

At millions of buildings and residences in the US, gas meters are protected only by a few concrete bollards. Unfortunately, when hit with any force by a 4,000-pound vehicle, they fail to do their job and often catastrophic gas leaks occur. And for falling snow, ice, and other external factors, bollards offer practically no protection whatsoever.

The HaloValve Natural Gas Safety Breakaway, which can be easily integrated into existing installations, is placed in the riser pipe between grade and the gas meter. Upon impact, the valve disconnects and gas flow is shut off, which provides instant and effective protection from the accidental rupture of gas meter lines.

Additionally, the HaloValve enables utility companies to comply with the requirements of the PIPES Act legislation of 2020 by helping eliminate the accidental emission of greenhouse gases into the atmosphere.

Visit HaloValve.com for more information

OPW 
ENGINEERED SYSTEMS
a  DOVER company



Designed to Break:

- The breakaway is installed into the meter set or other gas piping
- Design withstands nominal lateral forces
- If a significant lateral force occurs, the fitting breaks
- The ball acts as a plug stopping the escape of gas
- Stopping the flow of natural gas minimizes risk of fire, explosion, property damage and serious injury

There are several variables in determining the break force: speed of the force that is applied, distance from center of groove, direction of strike. For example, a break 10.5 inches from the center of the shear groove, perpendicular to the flow axis, would require a sudden impact average force of 155 lbs.

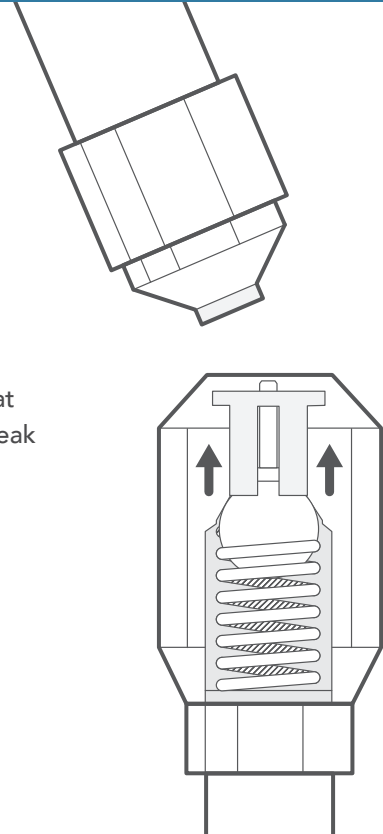

BODY:	Stainless Steel (ASTM A351 CF-8M)
SEAL:	Nitrile
PRESSURE RATING:	300 psi (21 bar) / 1000 psi (69 bar)
TEMPERATURE RATING:	-40°F – 212°F (-40°C – 100°C)
CONNECTIONS:	FNPT, MNPT
LINE SIZES:	3/4" (19 mm) and 1" (25 mm)
OVERALL LENGTH:	4" (102 mm) and 6" (152 mm)

Ordering Information

HALO - 075 - 4 - MM - HP

HALO	Size	Overall Length	End Connections (inlet x outlet)	Pressure
Natural Gas Safety Breakaway	075 = 3/4" 100 = 1"	*4 = 4" 6 = 6"	MM = MNPT x MNPT MF = MNPT x FNPT	HP = High Pressure (1000 psi) Blank = Standard Pressure (300 psi)

*4" length only available in the 3/4" size

Visit HaloValve.com for more information

US Master Distributor:



Pipeline Equipment Resources Company, LLC

Corporate Office
9 Mars Court
Boonton Twp, NJ 07005
t: 973-402-6664
info@perc.us.com
www.perc.us.com